

RICE TRAILERS

PRESTIGE, HAND-BUILT HORSE TRAILERS

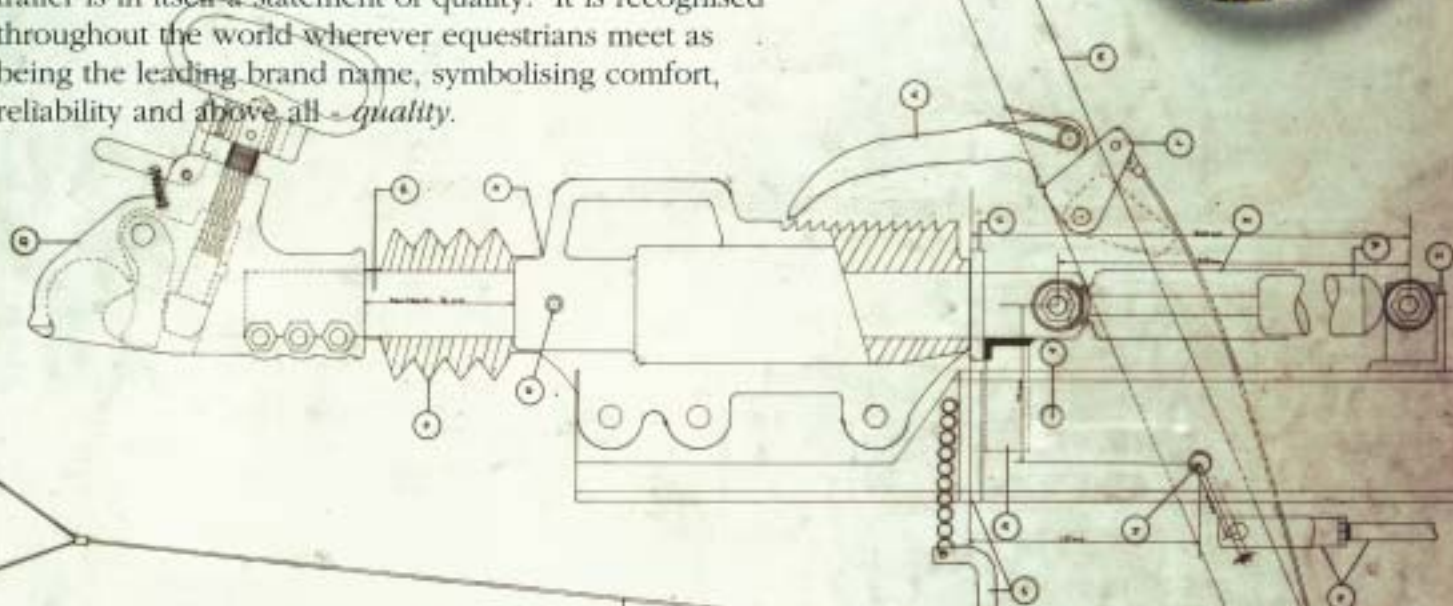

Rice Trailers have been making prestige, hand built horse trailers for nearly 70 years. The name Rice on your trailer is in itself a statement of quality. It is recognised throughout the world wherever equestrians meet as being the leading brand name, symbolising comfort, reliability and above all - *quality*.



'a Tradition of Quality'

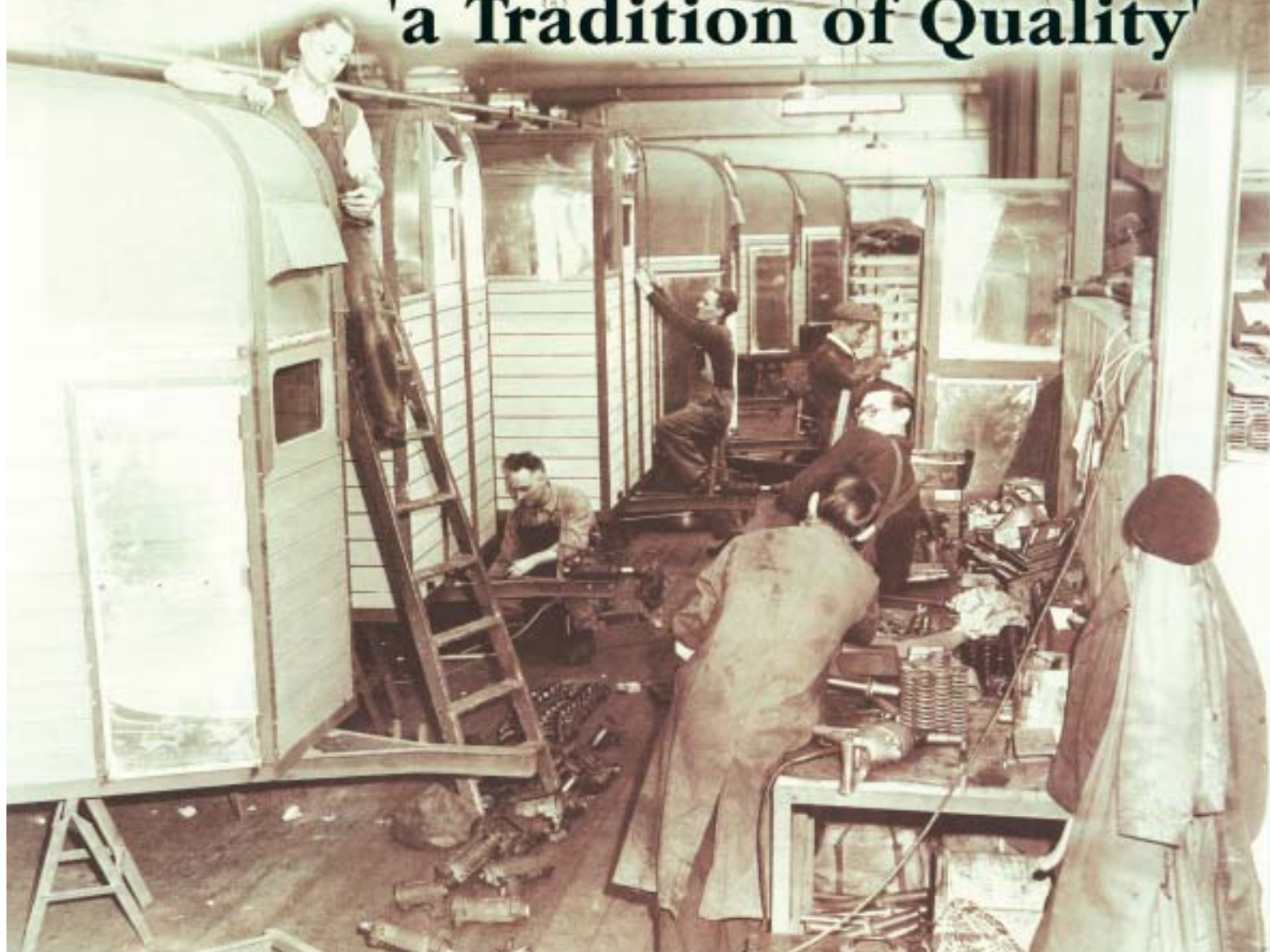

BEAUFORT DOUBLE



The Beaufort Double embodies all the qualities of engineering and design innovation for which Rice are internationally famous. This is evident in the very high specification that is fitted as standard. A double contoured timber floor, luxury full length side pads, fully padded swivel type partition (including padded breast/breech bars) all combine to provide a reassuring environment for your horse and make each journey stress-free. Its increased chassis and axle strength (from the Europa) make it capable of transporting 2 large horses with ease (gross capacity 2600kg). There is also an option available to increase the standard headroom from 7'0" to 7'6" if desired.

Rice Trailers



BEAUFORT 60



The new Beaufort 60 (B60) is a prestigious and stylish, high quality horse trailer from England's premier trailer manufacturer. It is derived from the very popular Rice Beaufort Double and is in direct response to the general public's demand for an extra large two horse trailer suitable for transporting horses weighing in excess of 700kg and standing 16.3hh and higher. Modern large horses of the Hannoverian, Trakehner and large Dutch breeds are frequently uncomfortable in a standard trailer, which is only 5'6" wide inside at the most. This trailer enables the larger breed of horse to stand with it's rear legs as far apart as possible, thus giving the horse confidence and security and increasing the trailer's safety and stability. Also featured as standard on this distinguished trailer are our stylised rubber ramp facings (including Rice logo), twin ramp assisters on rear ramp, large side windows and side vents.

BEAUFORT TREBLE



The Beaufort Treble, introduced and patented by Rice some forty years ago, has continually been developed and improved and this is the very latest design in its long history. It is a very versatile trailer, with its two and one loading arrangement and it is the perfect answer for carrying three horses (two 16hh and one at 15hh max) in comfort, safety and style. The innovative three horse partition allows you greater flexibility; you can close the front partition and move the split breast bars forward, thus transferring the weight correctly over the axles and maintaining the required nose weight for smooth towing. This also enables the room forward of the breast bar to be used for transporting tack, feed, a trap, etc. Again, in line with the B60, rubber ramp facings, twin ramp assisters on the rear ramp, large side windows and side vents are standard. There is also an option available to increase the gross capacity of this trailer to 3000kg if required.



.....'a Tradition of Quality'

EUROPA



The Europa is from the stable of the most famous, carefully planned range of horsebox trailers that load well, tow easily and have a certain dignity and practical elegance which made them the most popular without exception throughout the world. Not surprisingly this trailer enjoys widespread popularity as the ultimate in transport for two horses in the lightweight category. It can easily accommodate two horses of around 16HH, with a maximum combined weight of 1150Kg. The galvanised chassis and framework provide a durable, hardwearing framework, and when fitted with the aluminium roof and sides, together with a double layer timber floor, it really delivers a trailer built to last.

OVER 70 YEARS EXPERIENCE OF BUILDING QUALITY HORSE TRAILERS

As part of our policy to continually update the product range, we reserve the right to modify any specifications as may prove necessary. We will be pleased to answer any queries on this matter and confirm current specifications. All dimensions and weights are approximate and are intended for guidance only.

SCHEDULE OF DIMENSIONS

	Europa		Beaufort Double		Beaufort Double 7'6"		Beaufort 60		Beaufort Treble	
Weights	lb	kg	lb	kg	lb	kg	lb	kg	lb	kg
Unladen	1870	850	1936	880	2002	910	2398	1090	2728	1240
Capacity	2530	1150	3874	1720	3718	1690	3322	1510	2992	1360
Laden	4400	2000	5720	2600	5720	2600	5720	2600*	5720	2600*
Tyres	165 x 13		175 x 13		175 x 13		175 x 13		175 x 13	
Pressure	36 p.s.i.		54 p.s.i.		54 p.s.i.		54 p.s.i.		54 p.s.i.	
Dimensions	in	mm	in	mm	in	mm	in	mm	in	mm
Width	A Overall	86 2184	86 2184	86 2184	90 ¹ / ₂ 2298	90 ¹ / ₂ 2298	90 ¹ / ₂ 2298	90 ¹ / ₂ 2298	90 ¹ / ₂ 2298	90 ¹ / ₂ 2298
	E Inside	66 1676	66 1676	66 1676	70 ³ / ₄ 1797	70 ³ / ₄ 1797	70 ³ / ₄ 1797	70 ³ / ₄ 1797	70 ³ / ₄ 1797	70 ³ / ₄ 1797
Height	C Overall	104 2641	104 2641	110 2794	110 2794	110 2794	110 2794	110 2794	110 2794	110 2794
	D Inside	84 2133	84 2133	90 2286	90 2286	90 2286	90 2286	90 2286	90 2286	90 2286
Length	B Overall	175 4445	175 4445	175 4445	196 ³ / ₄ 5000	196 ³ / ₄ 5000	212 ¹ / ₂ 5400	212 ¹ / ₂ 5400	212 ¹ / ₂ 5400	212 ¹ / ₂ 5400
	F Inside	128 3251	128 3251	128 3251	140 3556	140 3556	150 3810	150 3810	150 3810	150 3810

*Option to upgrade to 3000kg available

Standard Specifications included on all Rice Trailers:

- ❖ Fully galvanised chassis & framework
- ❖ GRP nosecone incorporating cut away door above extra wide, full height front unload ramp
- ❖ Aluminium roof, rear top doors and body panels
- ❖ Auto reversing brakes
- ❖ Independent rubber suspension units with full width galvanised axle beams
- ❖ Hydraulic coupling complete with lock
- ❖ Spring assisted front and rear ramps
- ❖ Removable swivel type partition with padded breast and breech bars
- ❖ Full height locking grooms door
- ❖ Rear loading stands
- ❖ Spare wheel, cover and carrier
- ❖ Double timber floor
- ❖ Jockey wheel
- ❖ Heavy duty thermoplastic mudguards
- ❖ Large translucent fibreglass rooflight
- ❖ Perspex front window with vent over
- ❖ Interior light
- ❖ Interior tie rings
- ❖ Side vents in roof on all models except the Europa
- ❖ Paddings above full length galvanised steel kicking strips
- ❖ Wide range of standard colours

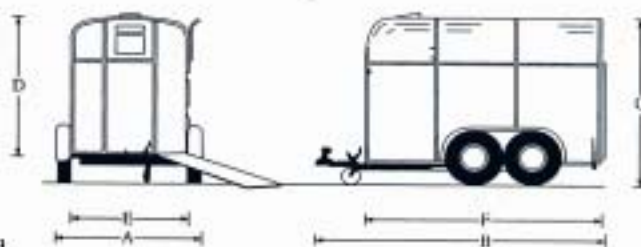

DISTRIBUTOR

RICE TRAILERS

Shipton-By-Beningbrough
York
YO30 1AB
Tel: (01904) 470282/470315
Fax: (01904) 470486
www.trailers-uk.com
email: info@trailers-uk.com